

Broaching Panel Fastener

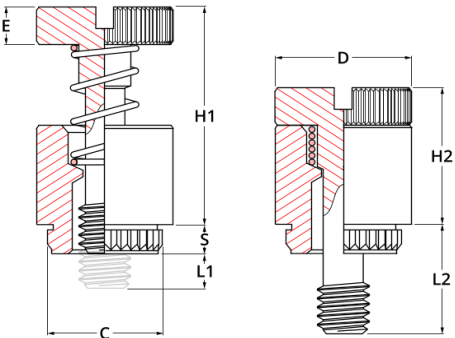

Broaching Panel Fastener												
Thread And Pitch	Screw Length Code	L1 + 0.64 - 0.64	L2 + 0.4 - 0.4	S Max.	C + 0.08 - 0.08	D + 0.25 - 0.25	E +0.13 - 0.13	H1 Nom.	H2 Max.	Minimum Panel Thickness	Hole Size + 0.08 - 0.0	Minimum CL To Edge Of Panel
M3 x 0.5	40	3	6.4	1.53	7.19	7.92	1.83	13.72	9.14	1.53	6.72	5.5
	62	3.2	9.4									
	84	6.4	12.7									

Material
Stainless Steel (A2)
Maximum Recommended Panel Hardness: 55HRB

INFORMATION AND DRAWINGS PROVIDED ARE FOR REFERENCE ONLY